

HEM

HYDRAULIC EXCAVATOR DRILLS



TEI ROCK DRILLS

PO BOX 1309, MONTROSE, CO 81402

(800) 777-3745 • (970) 249-1515 • www.teirockdrills.com

CATERPILLAR 314CL EXCAVATOR
HCF11 WITH TE350 DRIFTER

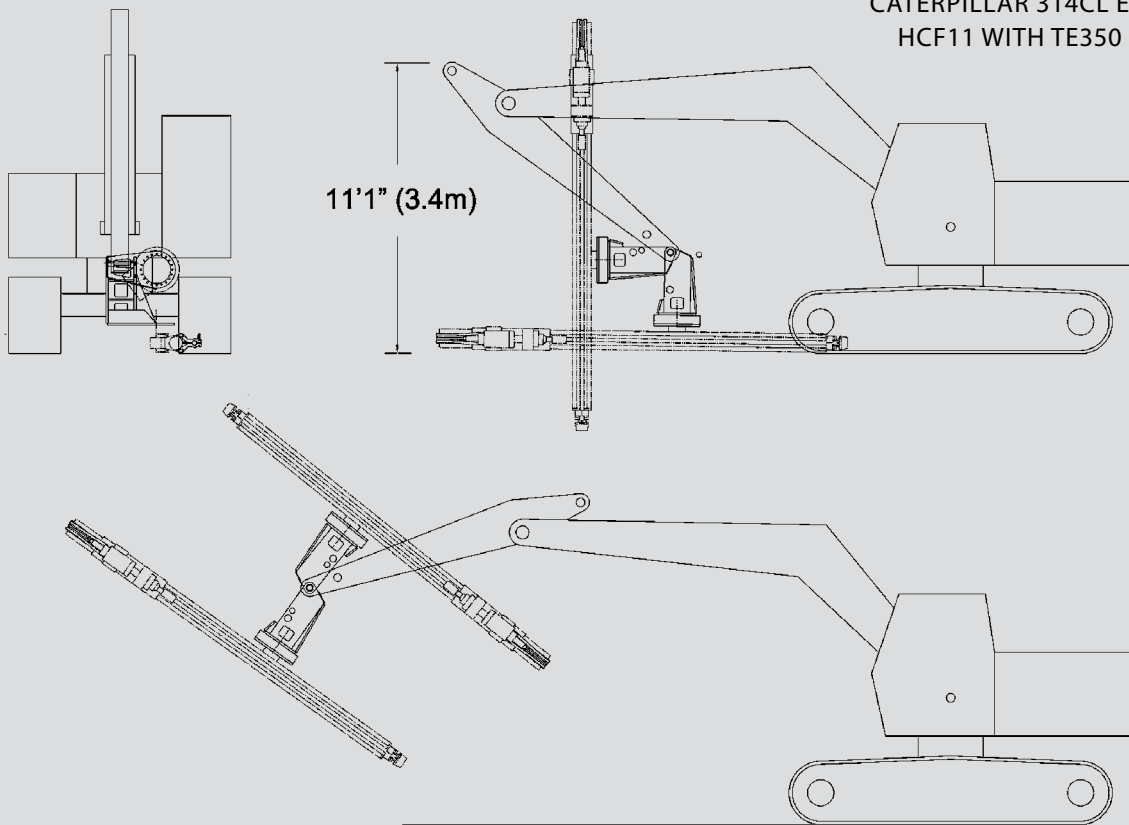

DRILL SPECIFICATIONS

Required Hydraulic Flow:

- TE350 35 GPM @ 2250 PSI - Minimum 14 Ton Excavator
- TE550 45 GPM @ 2500 PSI - Minimum 20 Ton Excavator
- RDS550 40 GPM @ 2500 PSI - Minimum 20 Ton Excavator
- RDSH1000 50 GPM @ 2500 PSI - Minimum 30 Ton Excavator

Approximate Attachment Weight:

- With HCF11 & TE550 - 3,500 LBS.
- Double Clamp add 350 LBS.

Total Drill Travel:

- With HCF11 - 10.5 FEET
- Total Length 16 FEET

Standard Equipment:

- 360 Degree Positioning
- Radio/Cable Remote Control
- Single Hydraulic Clamp
- Patented Drill Feed System

Optional Equipment:

- Double Hydraulic Clamp
- Misting Unit

ALL ATTACHMENT CARRIERS MUST BE PLUMBED WITH LOW PRESSURE RETURN AUXILIARY HYDRAULICS. AN ADDITIONAL HYDRAULIC OIL COOLER IS RECOMMENDED FOR PRODUCTION DRILLING. SPECIFICATIONS SUBJECT TO CHANGE WITHOUT NOTICE.



HEM300 INSTALLING TITAN ANCHORS



CONTROL BOX WITH RADIO RECEIVER



HEM550 BLASTING

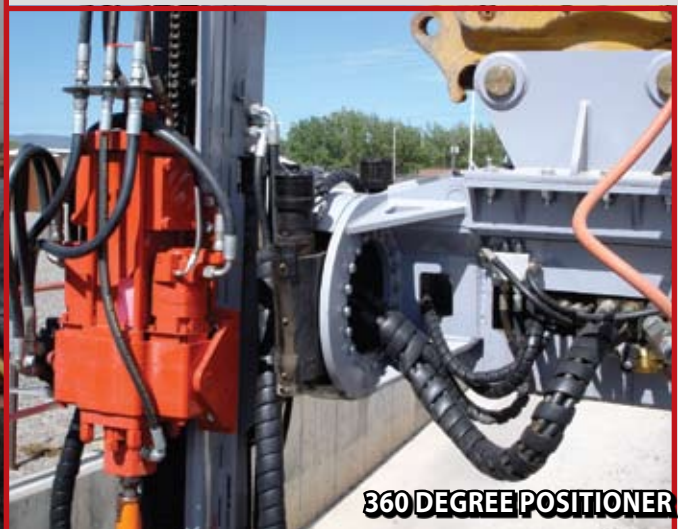

360 DEGREE POSITIONER

The **HEM (Hydraulic Excavator Mount)** is by far the most popular drilling attachment manufactured at TEI Rock Drills. The excavator provides a very stable drill platform with excellent reach and positioning of the drill mast. Today's modern excavators make it possible to use the 300 series of drifters up to some of the EuroDrill drifters and double rotary heads. With so many possibilities it's easy to see why so many civil and blasting contractors choose TEI's HEM line to get the job done. By looking at these photos you can see the unlimited possibilities with the HEM. Contact your TEI representative to help configure an excavator-mounted drill for your needs.

