



RDS350

ROTARY HEAD



TEI ROCK DRILLS

PO BOX 1309, MONTROSE, CO 81402

(800) 777-3745 • (970) 249-1515 • www.teirockdrills.com

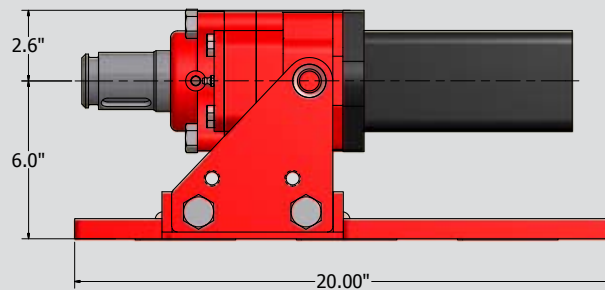
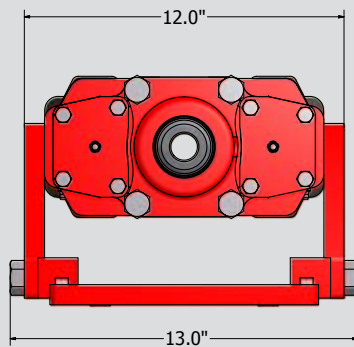
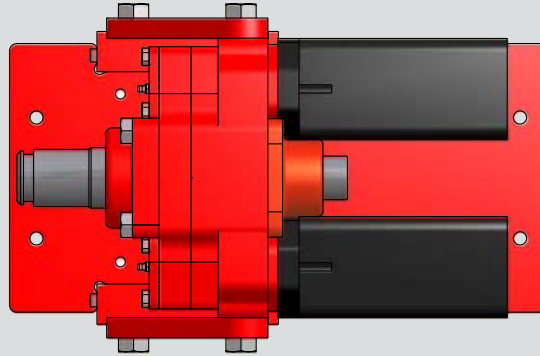
TE350 ON STANDARD 6" CENTER MOUNTING SLIDE.**Weight: 137 lbs.****DRILL SPECIFICATIONS****Stock output threads for RDS350:**

- 2 3/8 API Regular male and female
- 3 1/2 API Regular male and female
- 1 5/8 auger hex
- Other threads available

Specifications for the RDS350:

- Up to 180 RPM
- 2,000 ft/lbs of torque
- Hydraulic flow for 2,000 ft/lbs is 5 RPM per 1 GPM of hydraulic flow
- Hydraulic supply pressure 2250 PSI
- 3/4" JIC hydraulic connections
- 1" flushing ID on output shaft

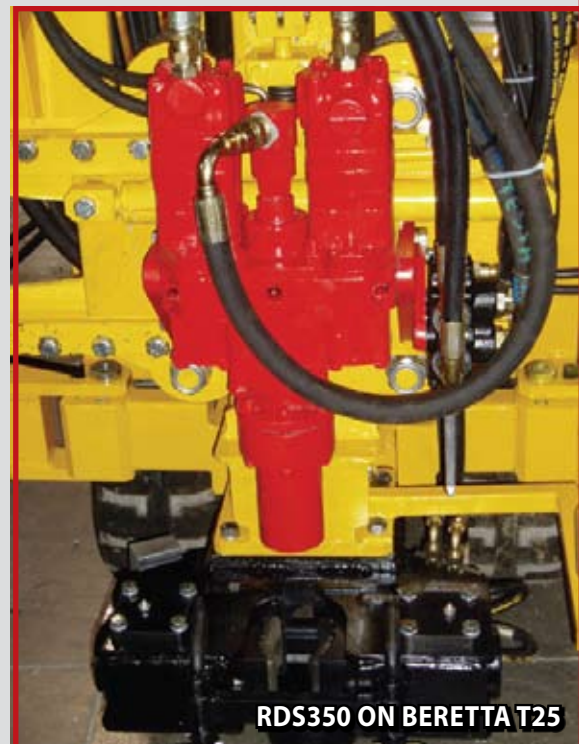
Used on PCF or HCF feed systems.**RDS350 ON BERETTA T25**

ALL ATTACHMENT CARRIERS MUST BE PLUMBED WITH LOW PRESSURE RETURN AUXILIARY HYDRAULICS. AN ADDITIONAL HYDRAULIC OIL COOLER IS RECOMMENDED FOR PRODUCTION DRILLING. SPECIFICATIONS SUBJECT TO CHANGE WITHOUT NOTICE.